

SPECIFICATION

LT P/N

LT2204WH-A-Q

R&D

Mass Product

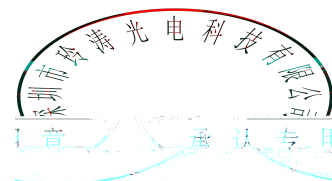

Contents

1. Description	3
1.1 General Description	3
1.2 Features	3
1.3 Application	3
1.4 Package Dimension	4
1.5 Product Parameters	4
1.6 Bin Range Of Forward Voltage and Luminous Intensity (IF=20mA)	BIN
(IF=20mA)	6
1.7 Typical Optical Characteristics Curves	9
2. Packaging	9
2.1 Packaging Specification	9
2.1.1 Carrier Tape Dimension	11
2.1.2 Reel Dimension	11
2.1.3 Label Form Specification	12
2.2 Moisture Resistant Packing	12
2.3 Cardboard Box	12
2.4 Reliability Test Items And Conditions	12
2.5 Criteria For Judging Damage	14
3. SMT Reflow Soldering Instructions SMT	14
3.1 SMT Reflow Soldering Instructions SMT	14
4. Handling Precautions	16
4.1 Handling Precautions	17

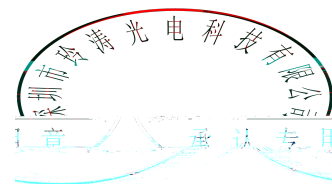

1. Description

1.1 General Description

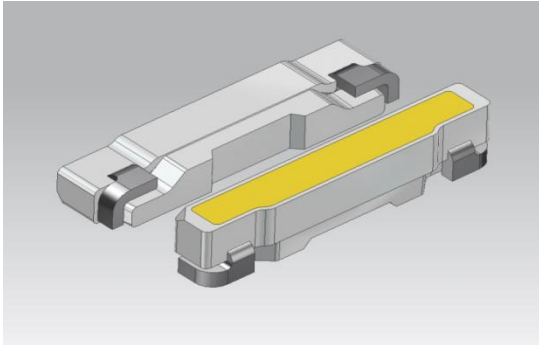

The White LED, which was fabricated by using a blue chip and the phosphor.

Product Package: 2.23mmX0.4mmX0.5mm.

LED, , : 2. 23mmX0. 4mmX0. 5mm

1.2 Features

PLCC Package. PLCC

Wide viewing angle.

Suitable for all SMT assembly and solder process.

SMT

Available on tape and reel.

Moisture sensitivity level: Level 3. Level 3

RoHS compliant. RoHS

1.3 Application

LCD Back Light. LCD

Mobile Phones.

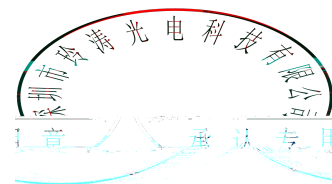
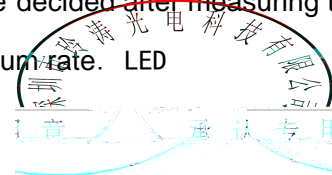

Table 1-2 Absolute Maximum Ratings at Ts=25°C

Parameter	Symbol	Rating	Units
Forward Current	I _F	30	mA
Peak Forward Current	I _{FP}	100	mA
Reverse Voltage	V _R	5	V
Electrostatic Discharge (HBM)	E _{SD}	2000	V
LED Junction Temperature (LED)	T _J	105	
Operating Temperature	T _{OPR}	-30 ~ + 85	
Storage Temperature	T _{STG}	-40~+100	

Notes

- 1/10 Duty cycle, 0.1ms pulse width. 0.1ms, 1/10.
- The above forward voltage measurement allowance tolerance is $\pm 0.03V$. $\pm 0.03V$.
- The above color coordinates measurement allowance tolerance is ± 0.003 . ± 0.003 .
- The above luminous intensity measurement allowance tolerance $\pm 3\%$. $\pm 3\%$.
- Care is to be taken that power dissipation does not exceed the absolute maximum rating of the product.
- All measurements were made under the standardized environment of LT.
- When the LEDs are in operation the maximum current should be decided after measuring the package temperature, junction temperature should not exceed the maximum rate. LED



1.6 Bin Range Of Forward Voltage and Luminous Intensity (IF=20mA)

BIN (IF=20mA)

Table 1-3 Bin Range Of Luminous Intensity Bin (IF=20mA)

BIN CODE	IF=20mA Test			
	Min(mcd)	Max(mcd)	Min(lm)	Max(lm)
30	2150	2250	6.00	6.25
31	2250	2350	6.25	6.50
32	2350	2450	6.50	6.75
33	2450	2550	6.75	7.00
34	2550	2650	7.00	7.25
35	2650	2750	7.25	7.50
36	2750	2850	7.50	7.75
37	2850	2950	7.75	8.00
38	2950	3050	8.00	8.25
39	3050	3150	8.25	8.50
40	3150	3250	8.50	8.75
41	3250	3350	8.75	9.00
42	3350	3450	9.00	9.25
43	3450	3550	9.25	9.5
44	3550	3650	9.5	9.75
45	3650	3750	9.75	10.0

Table 1-4 Bin Range Of Forward Voltage Bin

BIN CODE	Min.	Max.	Unit	Condition
V0	2.7	2.8	V	IF=20mA
V1	2.8	2.9		
V2	2.9	3.0		
V3	3.0	3.1		
V4	3.1	3.2		
V5	3.2	3.3		

Notes

VF Tolerance: $\pm 0.03V$ @ IF= 20mA @ Ta=25°C

IV Tolerance: $\pm 3%$ @ IF= 20mA @ Ta=25°C

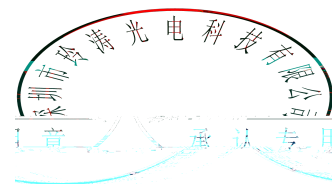

	0.2483	0.2181		0.2535	0.2181		0.2587	0.2181		0.2639	0.2181		0.2691	0.2181		0.2743	0.2181
	0.2440	0.2102		0.2492	0.2102		0.2544	0.2102		0.2596	0.2102		0.2648	0.2102		0.2700	0.2102
H12S	0.2431	0.2181	J12S	0.2483	0.2181	K12S	0.2535	0.2181	M12S	0.2587	0.2181	N12S	0.2639	0.2181	P12S	0.2691	0.2181
	0.2474	0.2260		0.2526	0.2260		0.2578	0.2260		0.2630	0.2260		0.2682	0.2260		0.2734	0.2260
	0.2526	0.2260		0.2578	0.2260		0.2630	0.2260		0.2682	0.2260		0.2734	0.2260		0.2786	0.2260
	0.2483	0.2181		0.2535	0.2181		0.2587	0.2181		0.2639	0.2181		0.2691	0.2181		0.2743	0.2181
H13X	0.2474	0.2260	J13X	0.2526	0.2260	K13X	0.2578	0.2260	M13X	0.2630	0.2260	N13X	0.2682	0.2260	P13X	0.2734	0.2260
	0.2517	0.2339		0.2569	0.2339		0.2621	0.2339		0.2673	0.2339		0.2725	0.2339		0.2777	0.2339
	0.2569	0.2339		0.2621	0.2339		0.2673	0.2339		0.2725	0.2339		0.2777	0.2339		0.2829	0.2339
	0.2526	0.2260		0.2578	0.2260		0.2630	0.2260		0.2682	0.2260		0.2734	0.2260		0.2786	0.2260
H13S	0.2517	0.2339	J13S	0.2569	0.2339	K13S	0.2621	0.2339	M13S	0.2673	0.2339	N13S	0.2725	0.2339	P13S	0.2777	0.2339
	0.2560	0.2418		0.2612	0.2418		0.2664	0.2418		0.2716	0.2418		0.2768	0.2418		0.2820	0.2418
	0.2612	0.2418		0.2664	0.2418		0.2716	0.2418		0.2768	0.2418		0.2820	0.2418		0.2872	0.2418
	0.2569	0.2339		0.2621	0.2339		0.2673	0.2339		0.2725	0.2339		0.2777	0.2339		0.2829	0.2339
H14X	0.2560	0.2418	J14X	0.2612	0.2418	K14X	0.2664	0.2418	M14X	0.2716	0.2418	N14X	0.2768	0.2418	P14X	0.2820	0.2418
	0.2603	0.2497		0.2655	0.2497		0.2707	0.2497		0.2759	0.2497		0.2811	0.2497		0.2863	0.2497
	0.2655	0.2497		0.2707	0.2497		0.2759	0.2497		0.2811	0.2497		0.2863	0.2497		0.2915	0.2497
	0.2612	0.2418		0.2664	0.2418		0.2716	0.2418		0.2768	0.2418		0.2820	0.2418		0.2872	0.2418
H14S	0.2603	0.2497	J14S	0.2655	0.2497	K14S	0.2707	0.2497	M14S	0.2759	0.2497	N14S	0.2811	0.2497	P14S	0.2863	0.2497
	0.2646	0.2576		0.2698	0.2576		0.2750	0.2576		0.2802	0.2576		0.2854	0.2576		0.2906	0.2576
	0.2698	0.2576		0.2750	0.2576		0.2802	0.2576		0.2854	0.2576		0.2906	0.2576		0.2958	0.2576
	0.2655	0.2497		0.2707	0.2497		0.2759	0.2497		0.2811	0.2497		0.2863	0.2497		0.2915	0.2497
H15X	0.2646	0.2576	J15X	0.2698	0.2576	K15X	0.2750	0.2576	M15X	0.2802	0.2576	N15X	0.2854	0.2576	P15X	0.2906	0.2576
	0.2689	0.2655		0.2741	0.2655		0.2793	0.2655		0.2845	0.2655		0.2897	0.2655		0.2949	0.2655
	0.2741	0.2655		0.2793	0.2655		0.2845	0.2655		0.2897	0.2655		0.2949	0.2655		0.3001	0.2655
	0.2698	0.2576		0.2750	0.2576		0.2802	0.2576		0.2854	0.2576		0.2906	0.2576		0.2958	0.2576
	0.2689	0.2655		0.2741	0.2655		0.2793	0.2655		0.2845	0.2655		0.2897	0.2655		0.2949	0.2655
H15S	0.2732	0.2734	J15S	0.2784		K15S			M15S			N15S			P15S		

	0.2904	0.3050		0.2956	0.3050		0.3008	0.3050		0.3060	0.3050		0.3112	0.3050		0.3164	0.3050		
	0.2956	0.3050		0.3008	0.3050		0.3060	0.3050		0.3112	0.3050		0.3164	0.3050		0.3216	0.3050		
	0.2913	0.2971		0.2965	0.2971		0.3017	0.2971		0.3069	0.2971		0.3121	0.2971		0.3173	0.2971		
H18X	0.2904	0.3050	J18X	0.2956	0.3050	K18X	0.3008	0.3050	M18X	0.3060	0.3050	N18X	0.3112	0.3050	P18X	0.3164	0.3050		
	0.2947	0.3129		0.2999	0.3129		0.3051	0.3129		0.3103	0.3129		0.3155	0.3129		0.3155	0.3129	0.3207	0.3129
	0.2999	0.3129		0.3051	0.3129		0.3103	0.3129		0.3155	0.3129		0.3112	0.3050		0.3164	0.3050	0.3259	0.3129
	0.2956	0.3050		0.3008	0.3050		0.3060	0.3050		0.3112	0.3050		0.3164	0.3050		0.3216	0.3050	0.3277	0.3129
H18S	0.2947	0.3129	J18S	0.2999	0.3129	K18S	0.3051	0.3129	M18S	0.3103	0.3129	N18S	0.3155	0.3129	P18S	0.3207	0.3129		
	0.2990	0.3208		0.3042	0.3208		0.3094	0.3208		0.3146	0.3208		0.3198	0.3208		0.3250	0.3208	0.3302	0.3208
	0.3042	0.3208		0.3094	0.3208		0.3146	0.3208		0.3198	0.3208		0.3250	0.3208		0.3302	0.3208	0.3354	0.3208
	0.2999	0.3129		0.3051	0.3129		0.3103	0.3129		0.3155	0.3129		0.3207	0.3129		0.3259	0.3129	0.3311	0.3129
H19X	0.2990	0.3208	J19X	0.3042	0.3208	K19X	0.3094	0.3208	M19X	0.3146	0.3208	N19X	0.3198	0.3208	P19X	0.3250	0.3208		
	0.3033	0.3287		0.3085	0.3287		0.3137	0.3287		0.3189	0.3287		0.3241	0.3287		0.3293	0.3287		
	0.3085	0.3287		0.3137	0.3287		0.3189	0.3287		0.3241	0.3287		0.3293	0.3287		0.3345	0.3287		

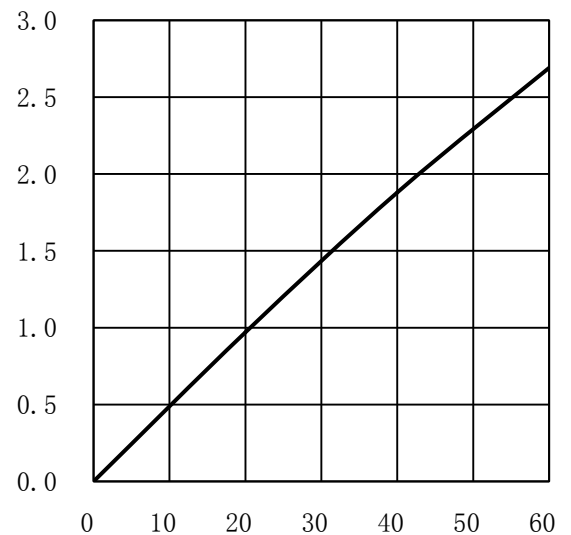

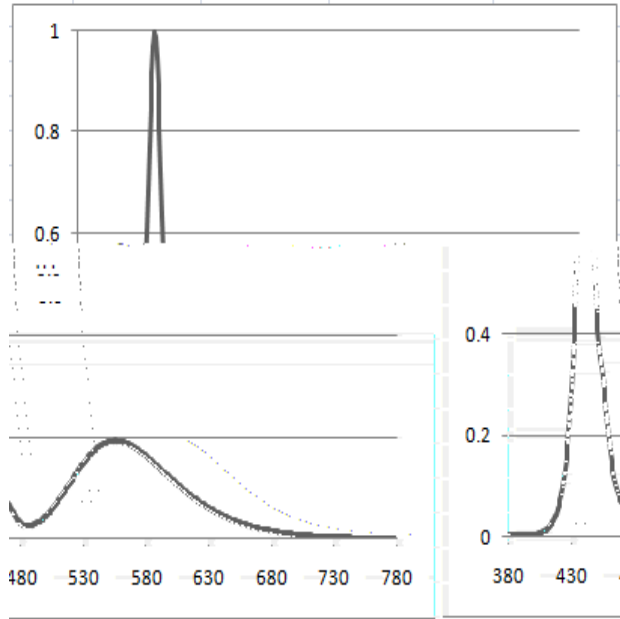

Fig. 1-9 Spectrum Distribution

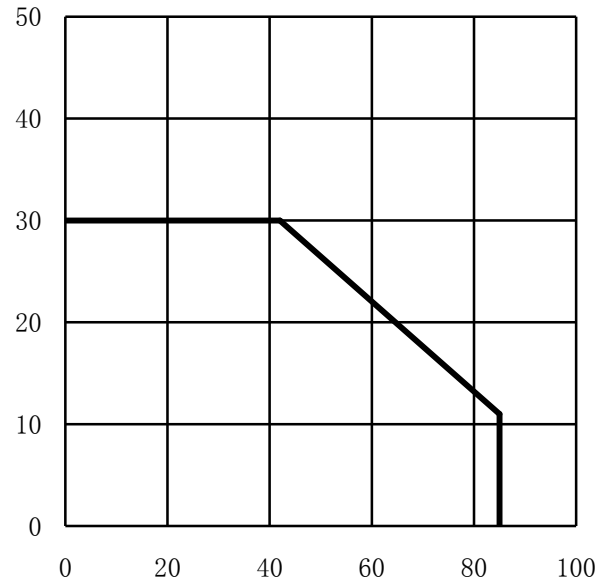

Fig 1-10 Solder Temperature Vs Forward Current

Tj 105

2. Packaging

2.1 Packaging Specification

A.Package:5000pcs/reel.

5000pcs

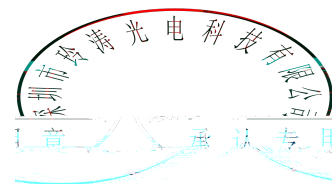
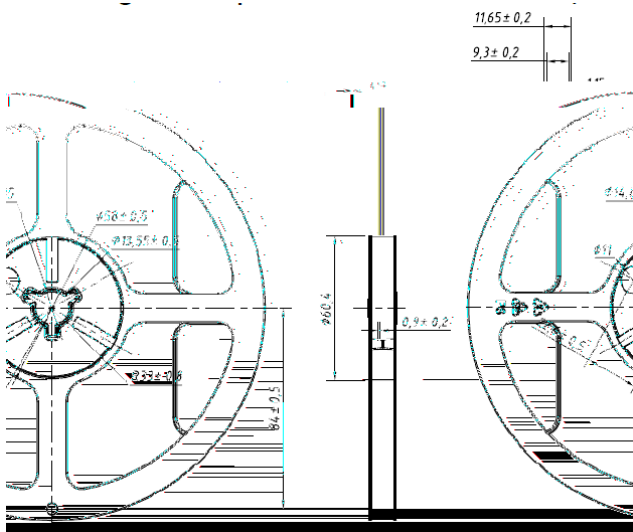

B.Package:10000pcs/reel. 10000pcs

Notes

When the quantity is less than 10000pcs/roll, the quantity is 5000pcs per roll.
5000pcs

10000pcs / ,

2.1.1 Carrier Tape Dimension

P0	4.00±0.10	P2	2.00±0.05	P1	4.00±0.10	D0	1.60±0.10	D1	0.80±0.10
E	1.75±0.10	F	3.50±0.10	W	8.00±0.20	A0	0.65±0.10	T	0.20±0.10
B0	2.45±0.10	K0	0.55±0.10						

Fig.2-1 Carrier Tape Dimension

Notes

2.1.2 Label Form Specification

Table 2-2 Label Map



Table 2-3 Label Form Specification

PART NO.	Part Number
BIN CODE	Bin Code
IV	Luminous intensity
V _F	Forward Voltage
WL	Wavelength
QTY	Packing Quantity
DATE	Made Date
LOT NO	Lot Number

2.2 Moisture Resistant Packing

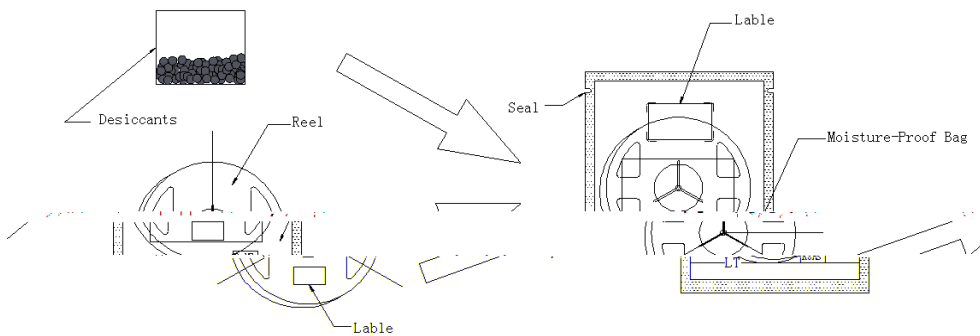
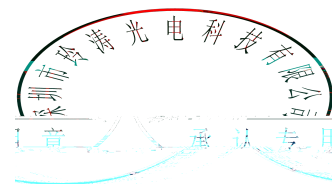

Fig.2-4 Moisture Resistant Packing

2.3 Cardboard Box



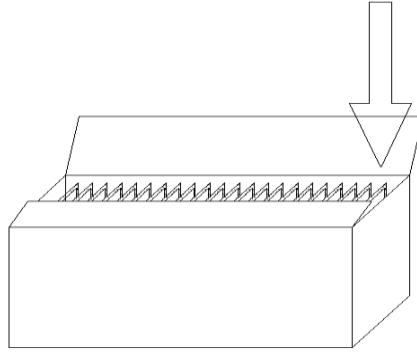
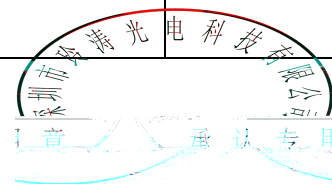

Fig.2-5 Cardboard Box

2.4 Reliability Test Items And Conditions

Table 2-6 Reliability Test Items And Conditions

TestItems	Test Condition	Time	Quantity	Ac/Re /
Reflow	Temp:260 max T=10 sec	---	20pcs.	0/1
Thermal Shock	-40 20min 10s 100 20min	100 cycle	20pcs.	0/1
High Temperature Storage	Temp:100	1000hrs.	20pcs.	0/1
Low Temperature Storage	Temp:-40	1000hrs.	20pcs.	0/1
Life Test	Ta=25 If=20mA	1000hrs.	20pcs.	0/1
High Temperature and Humidity storage	60 / 90%RH	1000hrs.	20pcs.	0/1
Temperature Humidity Operation Life	60 / 90%RH If=15mA	500hrs	20pcs.	0/1



2.5 Criteria For Judging Damage

Table 2-7 Criteria For Judging Damage

Test Items	Symbol	Test Condition	Criteria For Judgement	
			Min.	Max.
Forward Voltage	V_F	$I_F=20\text{mA}$	-	$>U.S.L^*)\times 1.1$
Reverse Current	I_R	$V_R = 5V$	-	$>U.S.L^*)\times 2.0$
Luminous Flux		$I_F=20\text{mA}$	$<L.S.L^*)\times 0.7$	-

Notes

- 1.U.S.L: Upper standard level L.S.L: Lower standard level
- 2.The above reliability tests is based on the verification of a single/strip LED of LT existing experimental platform,the reliability

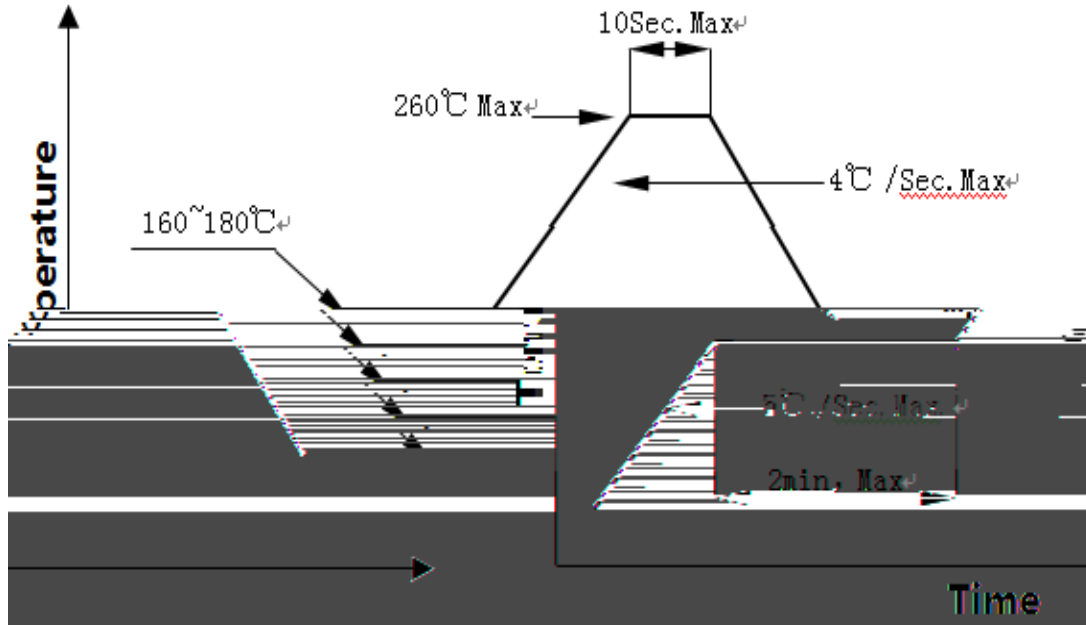

Fig.3-1 SMT Reflow Soldering Map

Fig.3-2 SMT Reflow Soldering Instructions SMT

Average temperature rise speed	T _{max}	T _P	5 °C/	Max 5 °C/ s
Preheating: minimum temperature	(T _{min})		160 °C	
Preheating: Max temperature	(T _{max})		260 °C	
Preheating: Time	T _{min}	T _{max}	60 - 120	60s-120s
Time limited to maintain high temperature: the temperature		(T _L)	217 °C	
Time limited to maintain high temperature: The Time		(t _L)	60	Max 60s
Peak /Classification of temperature:	/	(T _P)	260 °C	
Time limit classification of peak temperature time		t _p	10	Max 10s
(T _P) 5 °C		Hold time within 5 ° C with the	30	Max 30s
actual peak temperature (TP)				
Cooling speed			6 °C/	Max 6 °C/ s
25 °C		Needed time from 25 °C to T _p	8 min	Max 8 minutes

Notes

(1)Reflow soldering should not be done more than twice. If more than 24 hours between the two solderings , LED will be damaged. 24 LED

(2)Whensoldering , do not put stress on the LEDs during heating.

3.1.1 Soldering Iron

(1) When do soldering by hand, keep the temperature of iron below less 300°C less than 3 seconds. 300 3

(2) Soldering by hand should be done only one time.

3.1.2 Repairing

Repairing should not be done after the LEDs have been soldered. When repairing is unavoidable,a double-head soldering iron should be used (as below figure). It should be confirmed in advance whether the characteristics of LEDs will or not be damaged by repairing.

LED

LED

3.1.3 Cautions

(1) The encapsulated material of the LEDs is silicone. Therefore the LEDs have a soft surface on the top of package. The pressure to the top surface will be impacted on the reliability of the LEDs. Precautions should be taken to avoid the strong pressure on the encapsulated part. So when use the picking up nozzle, the pressure on the silicone resin should be proper. LED

LED

(2) Components should not be mounted on warped (non coplanar) portion of PCB. After soldering, do not warp the circuit board.LED



(3) Do not apply mechanical force or excess vibration during the cooling process to normal temperature after soldering. Do not rapidly cool device after soldering.

4. Handling Precautions

4.1 Handling Precautions

(1) LED operating environment and sulfur element composition cannot be over 100PPM in the LED mating usage material. This is provided for informational purposes only and is not a warranty or endorsement. LED LED 100PPM.

(2) In order to prevent external material from getting into the inside of LED, which may cause the

LED

(4) Handle the component along the side surface by using forceps or appropriate tools; do not directly touch or Handle the silicone lens surface, it may damage the internal circuitry.

(5) In designing a circuit, the current through each LED must exceed the absolute maximum rating specified for each LED. In the meanwhile, resistors for protection should be applied, otherwise slight voltage shift will cause big current change, burn out may happen. The driving circuit must be designed to allow forward voltage only when it is ON or OFF. If the reverse voltage is applied to LED, migration can be generated resulting in LED damage.

LED

LED

(6) Thermal Design is paramount importance because heat generation may result in the Characteristics decline, such as brightness decreased, Color change and so on. Please consider the heat generation of the LEDs when making the system design.

LED

(7) Compared to standard encapsulants, silicone is generally softer, and the surface is more likely to attract dust, requiring special care during processing. In cases where a minimal level of dirt and dust particles cannot be guaranteed, a suitable cleaning solution must be applied to the surface after the soldering of components. LT suggests using isopropyl alcohol for cleaning. In case other solvents are used, it must be assured that these solvents do not dissolve the package or resin. Ultrasonic cleaning is not recommended. Ultrasonic cleaning may cause damage to the LED.

LED

Table 4-1 Storage

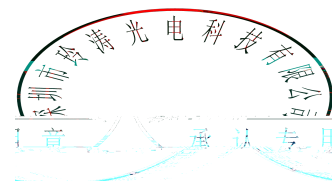

Version History/

Date	Revisor	Version	Verifier	Remarks
2020/06/20		E/0		

